

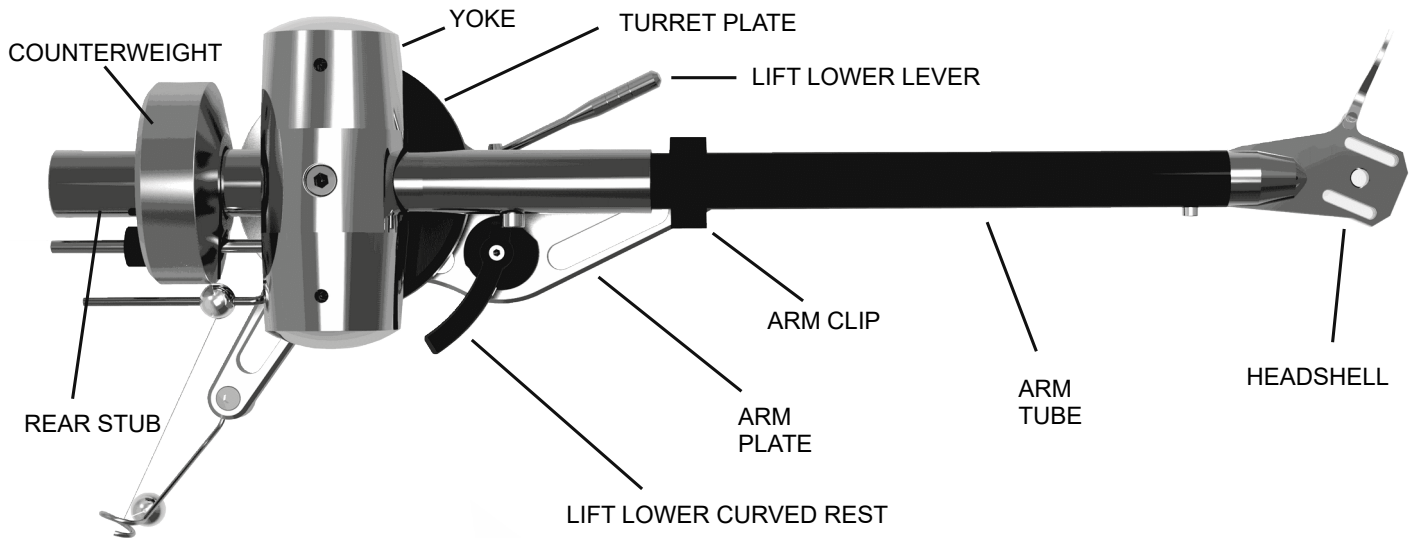

Instructions for Agile Tonearm

Manufactured by Origin Live ©



INTRODUCTION

Thank you for ordering an Origin Live arm. We trust you will enjoy getting closer to the original sound and appreciating your music in a new way.

Please give special attention to underlined text in these instructions.

Photos and diagrams cover a range of arms and illustrate concepts – do not expect exact representations of your specific arm.

Notes:

- a) It may seem there is “play” in the bearings - this is a design feature. The high grade bearings for horizontal and vertical movement are “floated” inside their housings to allow slight movement rather than rigidly coupling them to the structure. These bearings are self centering so you need not be concerned about apparent movement.
- b) The sound of new arms and rewires will improve significantly over the first 40 to 100 hours of running time as wires burn in.
- c) Do not loosen any bolts in the arm unless specified in this manual.
- d) You should handle the arm in exactly the same way as a conventional gimballed arm.

Mounting Requirements

Arm mounting varies depending on the make of your

turntable. This section caters for various scenarios.

Geometry & dimensions

You do not need a mounting template.

For standard Origin Live arms with effective length of 9.5 inch (239mm)

The arm mounting hole diameter should be 23mm to 24.5 mm.

Centre of mounting hole to centre of platter should be 222mm (plus or minus 1mm tolerance).

For 12 inch arms (309mm)

Dimensions are same as above, but mounting hole to centre of platter is 295.6mm

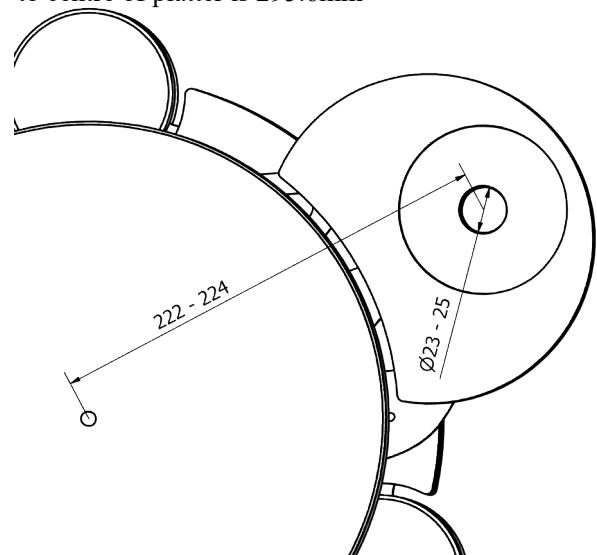

Height consideration

Origin Live arms can be raised by approx 16mm using VTA adjustment. However performance is optimized with the arm raised as little as possible. Ideally the height from the top of armboard to top of platter should be 24mm but not lower.

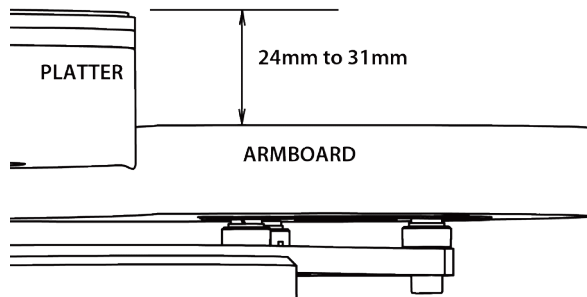

If this dimension is significantly larger on your deck, you can use spacing washers – a 4mm Acrylic washer is included for this purpose. This should be placed directly on top of your armboard before fitting the arm.

There are other methods of adjusting armboard height which may be advised by your turntable manufacturer.

Achieve Mounting Conditions

If your deck already has correct mounting dimensions then skip the next section and read “Mounting the Arm”.

If your deck does not yet have the correct geometry then alternatives are as follows.

Modify your existing armboard

You can probably modify your existing arm board to achieve the required geometry. Please refer to our web site.

Obtain a compatible armboard

Origin Live arm geometry is identical to that of Rega arms. This means they are perfect drop in replacements for all Rega arms. Many deck manufacturers cater for mounting Rega arms and can supply you with a Rega geometry armboard that will perfectly fit your Origin Live arm.

If necessary ask how to fit an “old style Rega geometry, threaded base mounting”? This is easier than the newer 3 point mount and may save you money. They should understand what is required.

Note that although newer Rega arms have a 3 point mounting, their armboards always have a central 24mm diameter hole and this is all you need to mount Origin Live arms.

If your arm has an SME mount there is an adaptor plate available on the Origin Live website – see Accessories > Vinyl > Adaptors

Mounting the Arm

Refer to diagram below.

1. Insert arm through mounting hole in the armboard.
2. Fit cork washer underneath the armboard.
3. Follow this with the large clamping nut and tighten to just finger tight.

The mistake is often made of over tightening this nut with the result that the music sounds deadened. Simply tighten to finger tight - as hard as you can. If you don't have a strong grip then use a spanner, pliers or mole grips to “nip” the nut a fraction tighter.

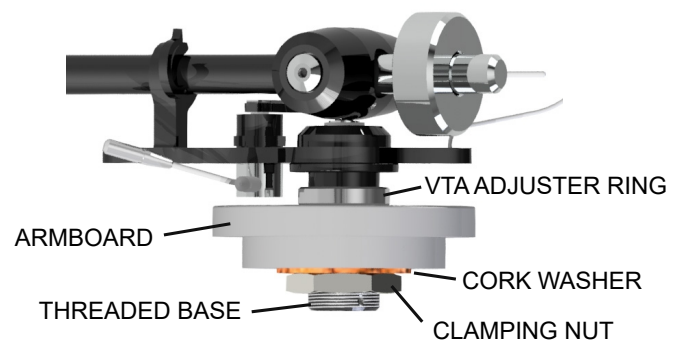

Remove Packing Spacer

Remove the rubber band from the plywood packing spacer as shown below and pull out the spacer. It helps to lift the yoke slightly as you do this.

Store the plywood spacer in a safe place as it will be needed if the arm is ever packed again for transit. The spacer is essential to ensure the pivot points are not damaged in transit.

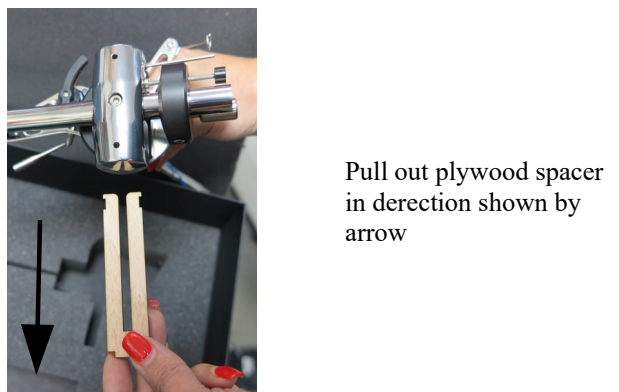
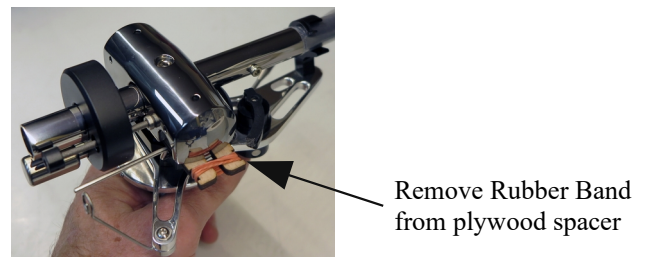

Agile Front View of Dual Pivot Arrangement

NOTE
It's not necessary to understand these diagrams. They're for information only.

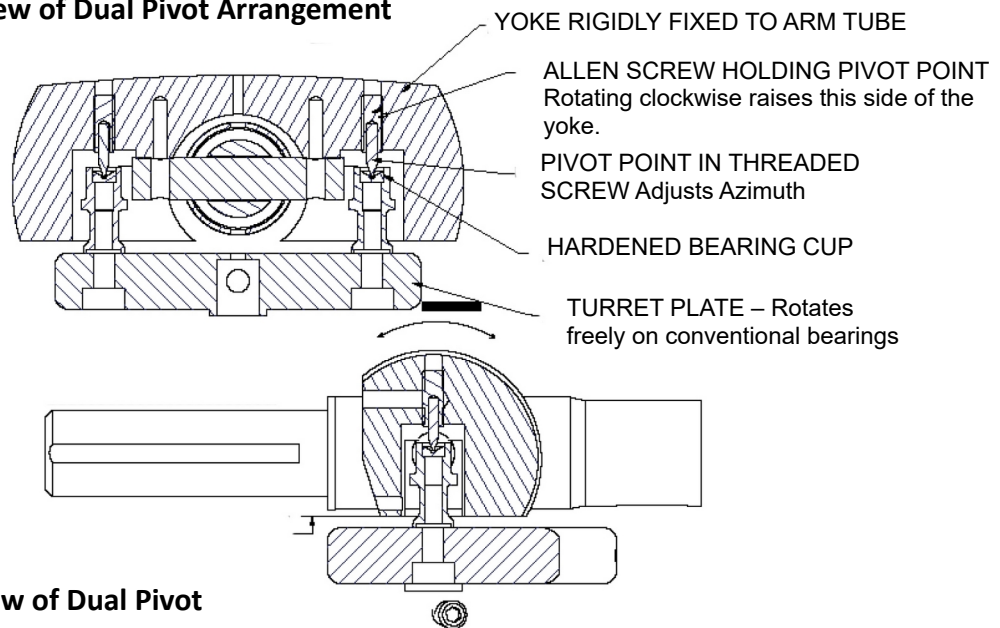

Side view of Dual Pivot

UNDERSTANDING DUAL PIVOT

Why dual pivot?

The innovative dual pivot bearing is one of the secrets behind this arms leading performance.

Similar in many respects to uni-pivots, the arm sounds fluid, easy on the ear, and transparent. These are the characteristics of low friction, well decoupled bearings.

The problem with uni-pivot arms is that they're fiddly to set up and produces mediocre bass due to their instability.

Dual pivots on the other hand have all the advantages of uni-pivots but none of the drawbacks.

- No wobble
- Easier set up
- Improved performance
- Better handling

How dual pivot works

The above illustration shows the dual pivot bearing which enables vertical arm movement.

Note that the horizontal axle is free to move a little in all directions within the "bearing cups"(except downwards). This may be a little disconcerting at first but confidence sets in after a little experience.

It's also reassuring to know the arm cannot be knocked off it's bearings or come loose in any way. You can turn the arm upside down and nothing will fall off as it would

in the case of a uni-pivot arm!

Self Centering Yoke

The pivot bearings are designed to reduce friction to an absolute minimum. To achieve both a robust design whilst maintaining extremely low friction, a sharp tungsten point locates on a shallow radiused bearing cup. Although the points can be forced to move sideways in the cup they always return to centre by gravity.

The "self centring" of the points in their cups may vary by 0.01mm or so which accounts for the slight deviance in tracking force of up to ± 0.06 grams. In practice this has no effect on performance and is also common among certain uni-pivot designs with very low friction bearings.

Some may argue that a very sharp point in a deep V shaped cup would restrain sideways movement better. However this increases friction levels significantly and uni-pivots employing this approach are exceedingly fragile.

CONNECT THE ARM

Fit Cable Clip

For optimal performance, support the arm cable with a clip fastened underneath the plinth. This helps prevent vibration feeding into the arm.

Leave a slight droop in the cable so it's not tight.

Clipping the cable is not always possible or convenient so may be omitted.

Connect the arm to your Phono stage / Amplifier

Plug the arm cable phono plugs into your phono stage (amplifier). You should ensure they are a reasonably tight fit to sockets. If this is not the case it pays to nip the outer jaws with a pair of pliers to close it up a little.

Earthing arrangements

Optimal earthing arrangement is largely a matter of trial and error as it depends on your phono stage / amplifier design. Most vinyl systems hum slightly at high volume levels, especially valve amplifiers. This can be reduced sometimes by changing the earthing arrangement.

Some of our external tonearm leads have a different number of earth leads so please read the section below that relates to your case.

Single earth wire on tonearm lead-outs

If your arm has a single earth lead, try connecting the blue tonearm earth wire to the **first** component in the chain from the arm. For example if you have a phono stage connected to an integrated amp, then connect the arm earth wire to the phono stage. On some amplifiers it's best to leave the arm earth disconnected to reduce hum.

3 Blue Earth wires and a Black signal return earth wire on tonearm lead-outs

If your arm has the configuration shown opposite, try the following and settle for the configuration with least hum.

A) Connect only the wire denoted "arm earth" and leave the "screen earths" and "black wire" disconnected.

B) Connect all 3 blue earth wires to earth.

Connect "2 blue screen earths" only and leave arm earth disconnected.

If hum still persists disconnect blue wires from earth and connect only the thin black wire sprouting from the "white RCA plug" to the phono earth.

Then try the options A to C but with the black wire connected.

This process does not take long and is only necessary if you experience hum.

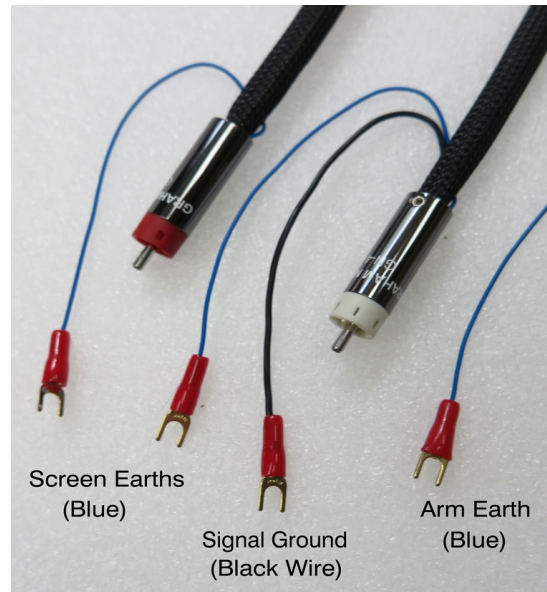

Additional notes on connections

Avoid pulling the external wires at the base of the arm as they are not indestructible and can become detached if excessive force is used to manipulate them. This also applies to the cable joints in the phono plugs.

If you have XLR plugs, you will not get both plugs through the mounting hole for the arm. The hole is too small to allow the 2nd plug to go through as the 1st cable wire takes up space.

For this reason we normally fit only one XLR plug and leave you to fit the other. Full instructions on how to fit the other XLR are available on our web site - see top navigation bar > Support > Solving problems > Tone-arms then scroll down to near end of page.

Fit Cartridge

If you're not familiar with fitting cartridges then please read the detailed section "Hi-Fi Cartridges explained" found towards the end of this manual.

Mounting

Mount the cartridge in the headshell using mounting screws (usually 2.5mm allen bolts).

At this stage the headshell screws should be just tensioned sufficiently to hold the cartridge against the headshell, but loose enough for the cartridge to be rotated and moved.

Set the initial position of the cartridge with mounting bolts approximately midway along the slots as shown below.

INITIAL POSITION OF CARTRIDGE

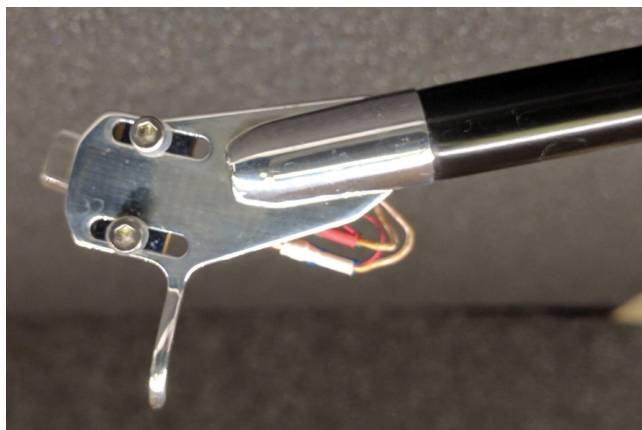

Carry out the set up procedure outlined below without deviating from sequence. Each step affects the next — change the order and setup will be wrong.

Notes on cartridge mounting

Once cartridge is later aligned, mounting bolts should be tight. Stainless steel Allen bolts are best for mounting cartridges – the aluminium or brass ones supplied with some cartridges are OK but difficult to tighten in comparison to Allen heads. Avoid steel bolts as they are magnetic and degrade your cartridge magnets.

It's safest to fit the cartridge with the stylus guard in place but it may be necessary to remove for phases of installation. If you do so, replace it as soon as possible.

Be especially careful when the stylus guard is off, as many MC cartridges have a strong magnetic field at the base of the cantilever. This can attract the tip of a steel-bladed screwdriver with irresistible force and destroy the stylus! To be safe, use a non-ferrous screwdriver, or keep the stylus guard on when you're using the screwdriver near it.

Fit the Counterweight

The Counterweight is already clamped to the arm and should never be removed - See Diagram.

Slacken the grub screw in the side of the arm just enough to allow the counterweight to slide back and forth along the rear stub. Do not undo this grub screw further or it will fail to hold an internal clamp (anti-clockwise unscrews). Re-assembly is not quick.

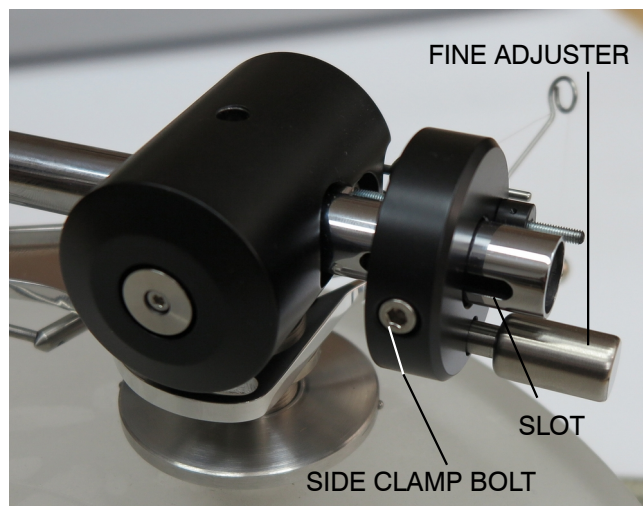

The tracking force is adjusted by sliding the counterweight along the rear stub and then clamping it firmly in position using the side clamp bolt. Fine adjustment can then be carried out by rotating the “Fine Adjuster”.

The small black “Setting Disc” on the threaded rod passing through the counterweight can be used as a reference point when positioning the counterweight. Once the counterweight is clamped you can improve sound quality very slightly by backing this off by about 1 turn so it is not touching the counterweight.

Misunderstandings of lift lower devices.

The lift lower device needs no adjustment but will only work correctly once the arm-tube is level (see VTA later).

It's a mistake to think variables such as cartridge body height affects the setting of the lift / lower device. Another misunderstanding is that if the platter height changes with the addition of say a platter mat, that the lift lower needs adjustment.

These misconceptions can cause a great deal of frustration. The lift / lower is factory set and works properly once the arm height is set correctly. “Correctly” means the arm tube sits parallel to the surface of the record when the cartridge has been lowered onto the record.

Correct operation of Lift lower device

When the lift / lower lever is raised the lever must travel past vertical to stay up. The arm will remain in this position with the cartridge lifted above the surface of the record.

Once you pull the lever back down to just past

vertical, the arm will gently fall till the stylus lands on the record surface.

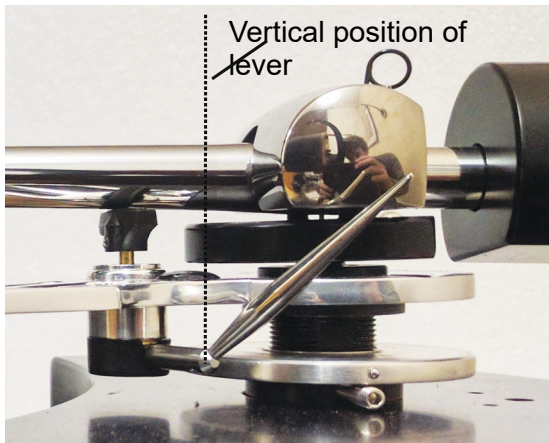

Photo showing lift / lower lever raised past vertical

Take care **not** to pull the lever down further once it's gone past vertical. This can stop the device functioning properly. Rather, once you've taken the lever past vertical just let the arm fall under its own weight.

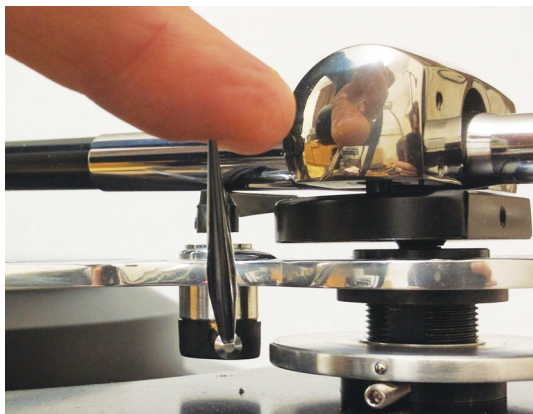
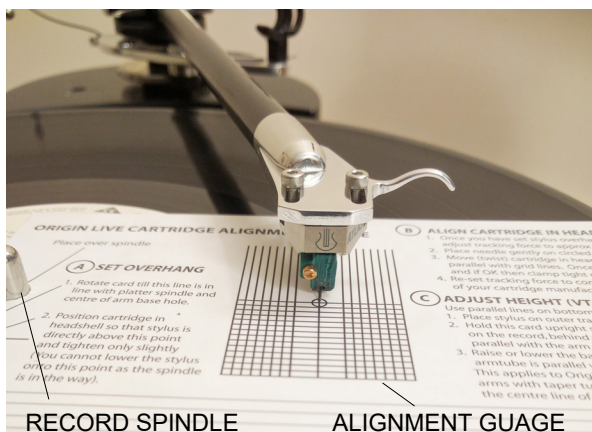

Photo showing lever at release point, just past vertical.

Descent rates vary on lift lower devices but a quick rate of descent is not a bad thing. This is similar to hand queuing records, which offers a very fast rate of descent. Notably hand queuing results in no degradation of records even when carried out mid track, hundreds of times. Slow descent on the other hand is more likely to “graze” a record and cause slight degradation.



RECORD SPINDLE ALIGNMENT GAUGE

Set initial tracking force

Set tracking force as specified by the manufacturer of your cartridge.

If you find the arm-tube is far from level, it may render tracking force measurements impossible, so adjust arm height accordingly. Read how to set arm height in next section.

Measure Tracking Force

To measure tracking force, use a stylus force gauge under the cartridge stylus as shown below.

Notes on Stylus Force gauges

Most stylus force gauges work on the same principle as a set of scales. For example with the Ortofon Stylus Force Gauge, first place the stylus on the inscribed portion of the scales. Then try the stylus at different points until you find the point where the beam “balances” freely in a roughly level position. You then read the force exerted.



Photo of stylus force gauge to set tracking force

From this number you can assess whether you need to increase the tracking force or vice-versa.

A digital force gauge works slightly differently so follow the manufacturer’s instructions.

Adjusting tracking Force

Before you start setting the tracking force, it helps to rotate the Fine Adjuster weight to approx half way along it’s travel. This will allow you to later fine adjust the tracking force by approx plus or minus 0.3 grams. Set tracking force by sliding the large counterweight to the correct position on the rear stub.

Slide the large counterweight till you achieve the correct tracking force to within 0.2 grams. Sliding the counterweight towards the cartridge increases tracking force and away decreases it.

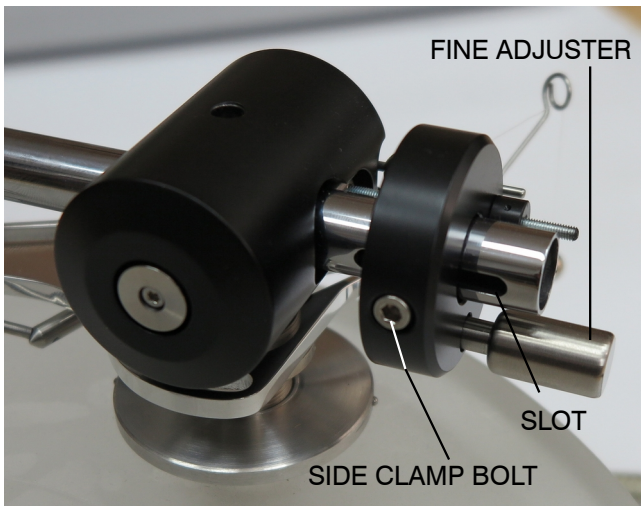

It can help to rotate the black plastic Setting Disc to rest against the counterweight thus giving it a reference position. Then firmly clamp the Counterweight in position using the side clamping bolt. This will not damage the bearings but do not clamp the bolt with all the strength you can muster as this can internally indent the rear stub.

Re-check that the tracking force is within plus or minus 0.2 grams of the cartridge manufacturer's recommended tracking force. Then use the fine adjuster to achieve a final accurate setting. If necessary repeat the procedure until the correct reading is obtained.

Once tracking force is set back off the black plastic setting disc by 2 turns or until it is just not touching the counterweight (touching degrades performance slightly). You may need pliers to initially rotate it clear.

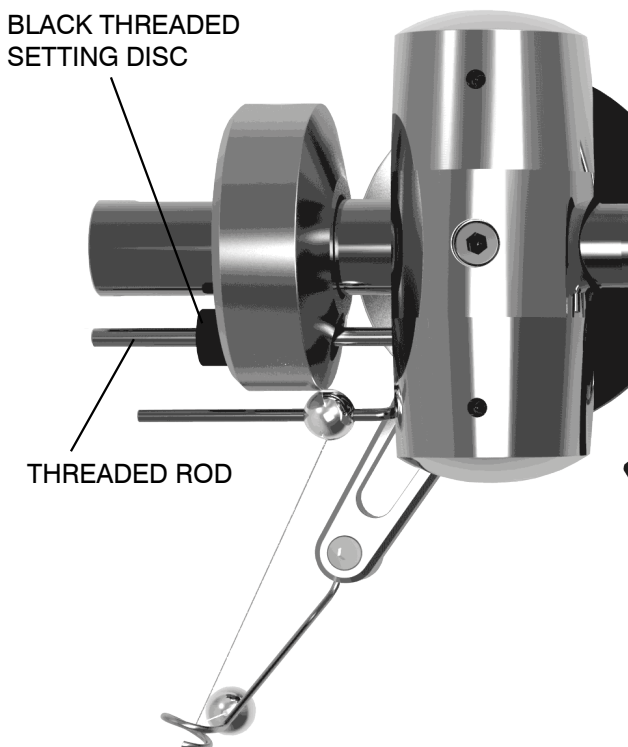

Set arm height

How to raise and lower arm base to set VTA

To raise or lower the base of the arm use the VTA adjuster ring – see diagram below.

The arm must be un-clamped for the adjuster to work. So slacken the large clamping nut to allow movement required.

Just under the arm plate is the thin silver VTA height adjuster ring – To raise the arm, turn the ring clockwise (anti-clockwise to lower it).

Judging correct arm height is described later but once achieved, clamp the arm using the clamp nut to tension described previously.

The wheel is capable of raising the arm around 16mm.

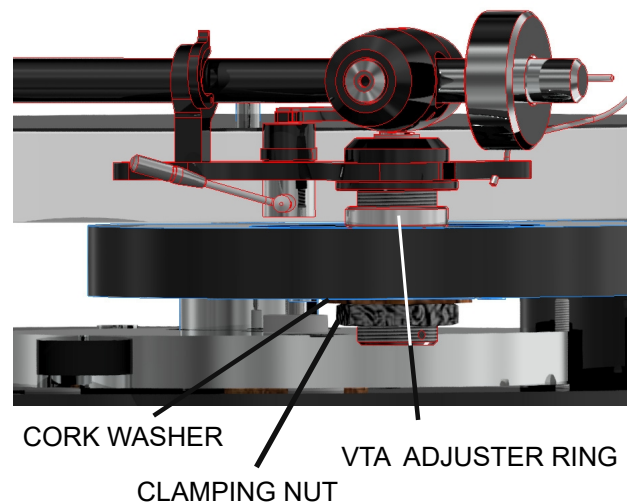

Adjust VTA

Set the arm height so that the arm tube is parallel to the surface of the record. This is fundamental for VTA and for the lift lower to work correctly.

To check arm height, lower the cartridge onto a flat record. Use a track position approx midway across the record.

Looking sideways across the arm, see if the arm tube is parallel to the horizontal lines on the alignment gauge. If the arm is down at the rear then raise the base of the arm and visa versa.

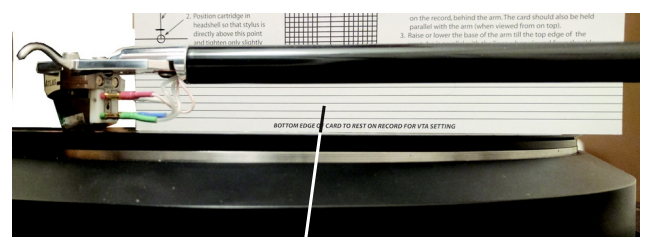

HORIZONTAL LINES ON ALIGNMENT GAUGE

To obtain an accurate assesment on parallel you must hold the card parallel to the arm tube in both planes as shown below.



Above photo shows correct orientation of alignment card



Above photo shows incorrect orientation of alignment card

Notes on VTA fine tuning

Cartridge suspensions “bed down” over the first 40 hours. There are also manufacturing variations in stylus angle tolerances.

For these reasons, final VTA tuning is best carried out by ear after this time period. There is a detailed Youtube video on how to do this on our Youtube channel.

Experimentally set the optimum arm height by listening to different VTA settings. If the arm base is too high, the sound is usually slightly on the bright side and lacking body in the bass – too low and it veers on the dull side.

Align Cartridge

For cartridge alignment, there are numerous Youtube videos which some may find easier than reading.

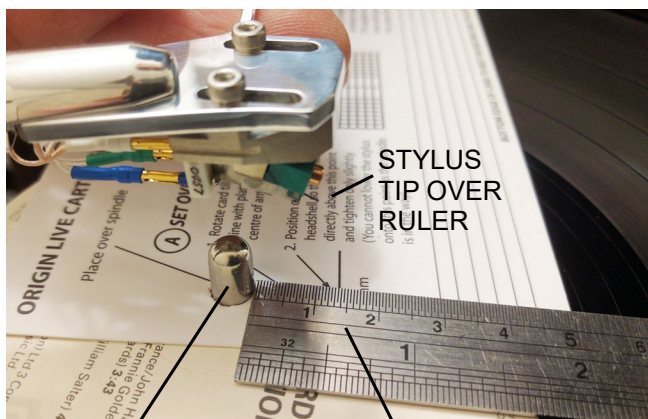

PLATTER
SPINDLE
7MM DIAMETER

USE RULER OR
MARK
ON ALIGNMENT
CARD

Set overhang

First set cartridge overhang to 17mm unless you have a 12 inch arm in which case the overhang is 13.2mm.

Overhang is the measurement from centre of platter to tip of stylus (see below). When measuring this ensure the arm-tube is positioned with it's centre line directly over the centre of the spindle as shown.

Use the alignment gauge or a ruler to judge this measurement. In the above photo, notice that the ruler is butted against the spindle although it's the centre of the spindle that we need to measure from. To compensate for this simply add 3.5mm (half the diameter of the spindle) to measurement readings. This is easier than trying to align the ruler with the centre of the spindle.

Note that when you later twist the cartridge to align it, the overhang position must be maintained and checked at the end of the whole procedure.

Line up the stylus

Once overhang is set, place the alignment gauge on the platter as shown below.

Gently lower the cartridge onto the alignment gauge and follow the instructions printed on it. Twist the cartridge body in the headshell till body or stylus aligns with grid then re-check overhang. Repeat procedure if necessary till desired result is achieved.

When all adjustments are correct, carefully tighten down the cartridge mounting screws keeping a firm grip on cartridge and headshell together so nothing shifts.

Gradually tighten each screw in turn until tight. Tightening one screw fully before tightening the other is almost certain to move the cartridge out of alignment. However careful you've been, always check the alignment again after tightening.

Ensure the headshell wires are bent so they are clear of the record surface. Align stylus or cartridge body?

Most cartridge bodies have faces that are perfectly aligned with the cantilever so you can align the cartridge body on the gauge.

However this does not apply to all cartridges and some brands do not build their stylus aligned symmetrically with the body.

In these cases align stylus along centreline of the card. This takes precedence over cartridge body alignment in the case of Lyra, Soundsmith and other cartridges.

Reset tracking force if necessary

Now that your cartridge is adjusted you will almost certainly find that your initial tracking force reading has changed.

ALIGN STYLUS AS THE PRIORITY

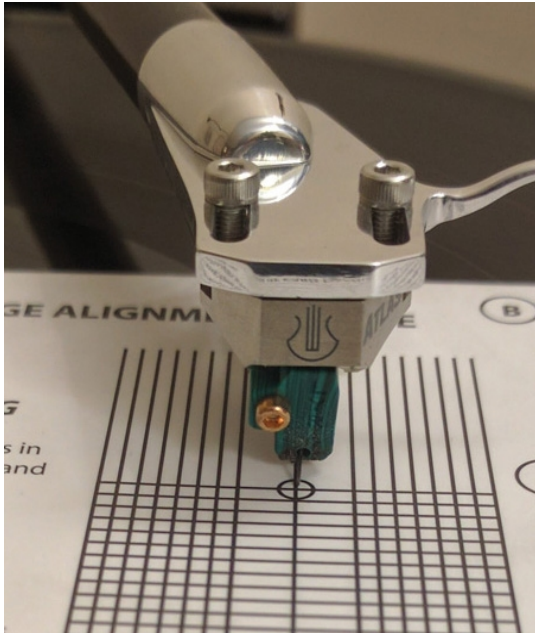

CENTRE LINE
OF
ALIGNMENT
GUAGE

Re-set the tracking force to it's correct reading using the same procedure as before.

SIDE BIAS

Side bias (sometimes called "Anti-skate") applies an opposing (outward) balancing force, to the natural **inward** drag of a pivoting arm while playing. Left uncontrolled, the stylus would push up against the groove inner wall, causing distortion both from mis-tracking and a cantilever skewed in relation to the cartridge generator.

Orientate wire loop (packed position is temporary for transit only)

Orientate the wire loop to be roughly in line with the arm plate protrusion as shown. You can then tighten the grub screw in the top of the Wire Loop Base to clamp it in position, using the Allen key supplied.

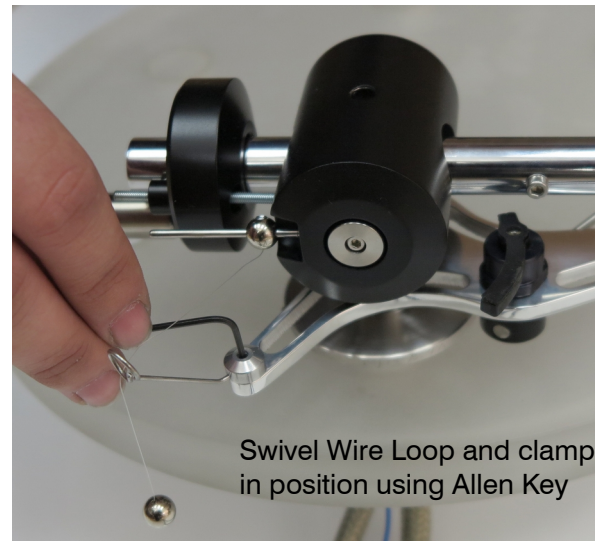
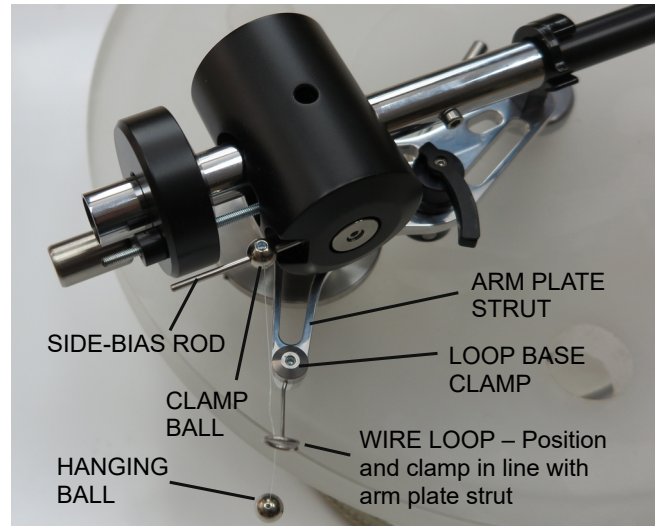

The wire loop position can also be adjusted vertically using the set screw in the underside of its Base adjuster. This is set at factory to be level with the side bias rod and normally needs no attention.

Fit side bias balls

Carefully unpack the 2 balls and joining thread (shown in below).

SIDE BIAS ARRANGEMENT

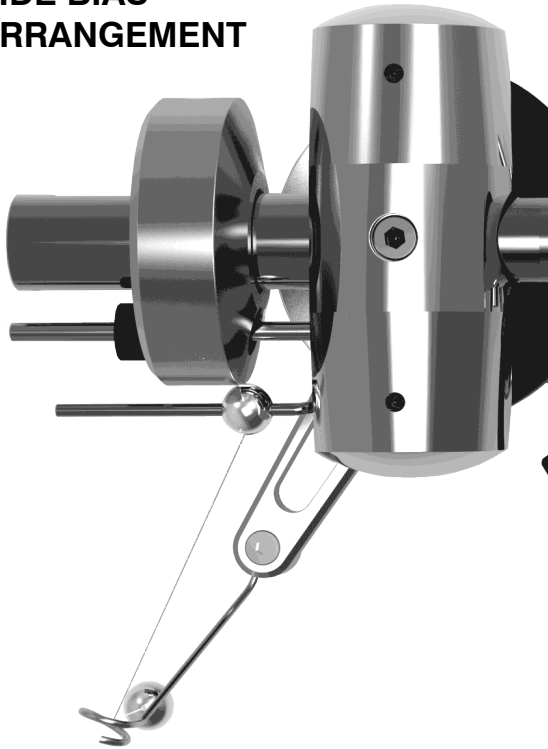

Fit the “clamp ball” which slides along the side bias rod. Lightly clamp in position (approx 2mm away from the yoke) using a 1.5mm Allen key in the tiny set screw of the ball.

Thread the thin nylon filament line through the small gap of the wire “eye” to allow the ball weight to hang freely.

Side bias force is set by varying the position of the clamp ball along the rod. To increase side bias, un-clamp the ball and move it outwards. To decrease side force move the ball inwards.

Once correct position is finalized, clamp the ball in position.

It's possible that the hanging ball can foul the wire loop when the arm gets close to the end of the record. If this occurs simply bend the wire loop downwards near the base, whilst at the same time increasing the bend thus pulling the “loop” portion closer.

Setting side bias

Reliable Method

There are various methods of checking side bias. Some are controversial and we would suggest that by far the most reliable method is to listen to music with the clamp ball in various positions along the rod. You will notice that when the ball is in a certain position that the music

seems to snap into slightly more focus with better separation, and vocals become more pinpoint rather than diffuse and wide. The best position on the record for listening to side bias is approximately two thirds of the way across the record. This slight bias towards the inner tracks is because the cartridge has a harder time negotiating the inner grooves.

Test Record or blank vinyl

You may not trust your ears and wish to use other methods. One is to use a test record or a record with approx 10mm of blank vinyl between the end of the lead out groove and the record label. Lower the stylus needle on the blank uncut vinyl and observe whether the needle skates inwards towards the centre of the record or outwards. Increase anti-skate until the arm starts to slowly drift inward towards the label. This particular method is only a very rough guide as it does not simulate the additional friction forces of the needle in the groove.

Watching the cartridge Cantilever as it lands in the groove

Also, watch the stylus when you set it into a groove. Does it move to the right or left relative to the cartridge body? This indicates too much or too little anti-skating.

Test Record

You can use a test record with a track for checking side bias (not all have this so check before you buy. The Ultimate Analogue Test LP is recommend as it has an Anti-skating test; 315Hz amplitude sweep to +12dbu (Lateral). Also the Hi Fi News test record has an Anti-skate/bias setting track.

We urge caution on using this method as Peter Lauderman founder of SoundSmith Cartridges has pointed out that when he examines cartridges, many are more worn on one side of the stylus from excessive side bias. This excessive setting is due to the grooves on most test records being too heavily modulated to be representative of actual records.

For fine tuning of the side bias we recommend the video on our Youtube channel. Titled “setting Side Bias”.

Experimentation

Finally for those who wish to experiment with varying side bias drag across the record it's worth mentioning that side bias can be increased on the

inner grooves by rotating the wire loop away the cartridge, and decreased by rotating the wire loop away from the cartridge.

Azimuth

Azimuth is the vertical alignment of the cartridge / stylus as shown in diagram.

This is correctly set at factory and we recommend that you do not adjust this unless you have the measurement tools to do so correctly. There are various tools for carrying out azimuth checks such as Dr Feickert, mirrors and microscopes. These are all explained by their manufacturers.

It's also absolutely critical to adhere to our instructions or the arm will probably end up not working correctly.

Never use the small bolt in the side of the tube near the headshell to adjust azimuth – only the single bolt shown in diagram.

Also never unscrew the other cap head screw in the same side of the arm tube.

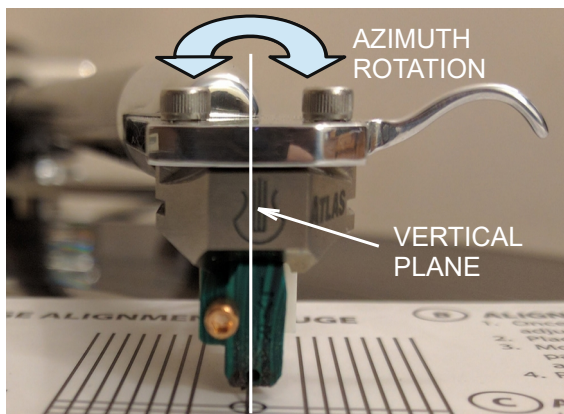

Adjusting Azimuth

If you wish to adjust azimuth, do so by slackening only ONE “Azimuth clamping screw” on the nearside of the arm – this is shown in the diagram shown below.

Adjust azimuth by inserting a 1.5mm Allen key into the relevant top hole in the yoke and locating it in the Allen socket of the “Azimuth pivot adjuster screw” (see below).

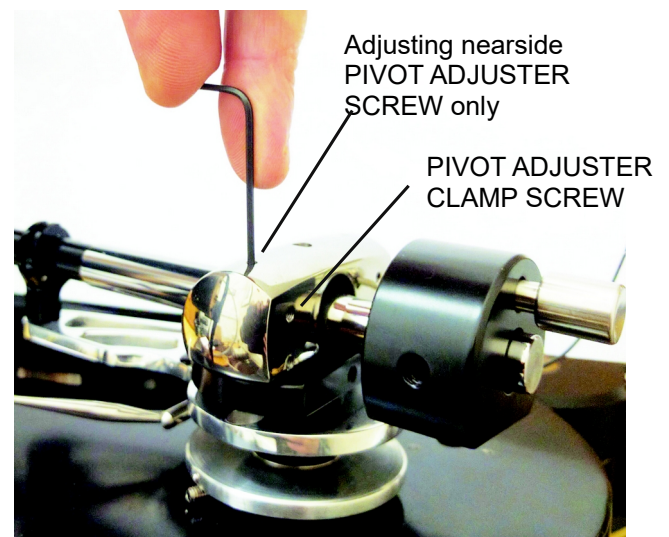

Make a mental note of the orientation of the Allen key elbow so that you can remember the original factory set position and keep a record of the fractional turn you give it e.g 1/4, 1/16 etc.

Never turn the Allen key more than 1 turn either way out of this position or you risk crushing the spikes.

Turning the Allen key clockwise will raise the yoke on the nearside, anti-clockwise will lower it. You only need a small fraction of a turn to make a big difference to the azimuth.

Never adjust the azimuth pivot adjuster screw on the far side as this maintains a reference height.

Once you are satisfied with the new azimuth setting, lightly re-tighten the Azimuth clamping grub screw and re-check the azimuth as there is a remote chance that it can move due to clamping. If this occurs then reset the azimuth without slackening the clamping screw any more than necessary to enable the azimuth adjustment screw to still turn.

Check dual pivot bearings work properly

The stylus down force should be consistently accurate to within plus or minus 0.06 grams (i.e = 0.12mm total variation). Higher deviations indicate

that the bearing might be damaged or incorrectly adjusted.

The bearing freedom of movement should be checked by measuring the stylus down force over a succession of 10 or so movements of the arm into the arm clip and then onto a stylus force gauge. The force gauge should read consistently to within plus or minus 0.06 grams over the 10 measurements if all is well.

It's best to use a digital force gauge as a "balance" type can give inconsistent readings of up to 0.5 grams .

Fine Tuning

You now have three adjustments approximated. Tracking force, VTA, and Azimuth. Fine tuning is best carried out by listening. If you wish you can experimentally move from one type of adjustment to the next, then to the next, in order to balance the optimization for all three.

Some cartridges like Lyra and Dynavector are very consistent. The manufacturers recommended tracking force is always spot on so all you need adjust is VTA.

Others such as London Decca and Soundsmith benefit from a little experimentation with force but never wander outside the recommended range.

It's helpful to listen to female vocals as you proceed. Firstly try deviating from the cartridge's recommended tracking force by small increments - about 0.2 of a gram deviation above and below the manufacturer's basic recommendations. Don't worry about record damage from heavy tracking as most record damage is actually caused by mistracking from too little tracking force rather than with too heavy.

If you're getting mistracking at the low (lightest) end of the range and yet the low range is generally sounding the best (and on moderate signals, not heavy passages), then chances are you have either a dirty stylus, a bad record, an accumulation of crud in your cartridge, or a cartridge that's getting old. Changes in tracking force can change the optimal VTA adjustment.

WARRANTY

We guarantee arms to be free from fault for 5 years and will undertake remedial work, providing the arm has not been modified by any party other than ourselves and has not received maltreatment of any kind.

FAULTS

In the event of a perceived fault, please refer to our website > support > solving problems > Tonearms.

Notes

Rustling noise from sudden arm movement

Please note that the arm can make a slight "rustling" noise through the speakers when it is lifted across the record. This should not be a cause for concern as it is only caused by microphony of the internal litz cable - under normal playing conditions this is inaudible.

Lift / Lower device height adjustment

If the arm does not raise and lower to the correct height then it can be adjusted by undoing the tiny M2.5 Allen bolt in the top of the curved arm rest. Lift the curved rest off the top of the piston and add or remove small spacing washers to raise or lower height according to need.

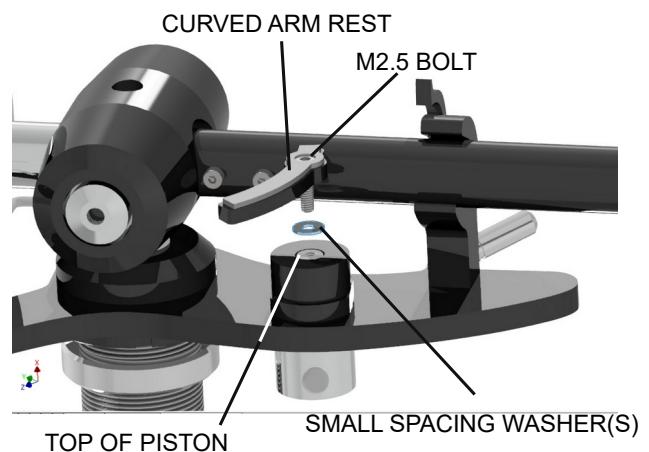

Diagram showing small spacing washers which set height of curved rest

If the arm "sticks" (mistracks) playing a record

Check that the curved arm rest is not fouling on the yoke. Hold the arm finger lift and check that the arm can traversed by hand above the surface of the whole record. This will identify the position of the "stick" – simply rotate the arm rest till it no longer fouls – this can usually be carried out without loosening the arm rest grub screw.

Another potential cause is headshell wires drooping down and touching the record.

Allow burn in of wires

The sound of new arms and rewires will improve significantly over the first 2 weeks as items "bed in" and arm wires **burn in**.

Now that all the hard work is over you can settle back and hear the results - we wish you many hours of enjoyable music and rediscovering your record collection.

CARTRIDGES EXPLAINED

Optional reading for less experienced users

General Notes

Origin Live offer most makes of hi-fi cartridge so we get asked questions about various issues regarding set up and care. To help newcomers to this area we have published the following notes. These guidelines are of a general nature - we publish them only to be of help and although widely accepted they are not formally authoritative - we cannot accept liability if you choose to use them and neither do we encourage the time consuming occupation of answering queries surrounding the procedures outlined - these are best referred to the manufacturer of your specific hi-fi cartridge.

For those new or inexperienced to fitting hi-fi cartridges we would state that this is NOT difficult and much of the detail and perfectionism outlined below is for those who like to experiment. We ourselves do not normally check azimuth, or vary tracking forces from the manufacturers recommendations - neither would we worry if the arm was up to 1mm away from the recommended distance from the spindle - although all these details are audible they are generally of a relatively low order, however tracking force and VTA in particular are worth fine tuning should you feel anything is lacking. If things seem complicated we would encourage you not to be put off as it all becomes clear once you get started.

Before fine tuning the set up as described below you should allow the cartridge to "run in" properly - at least 40 hours for some cartridges.

Importance of set up

Hi-Fi cartridges travel like a bobsleigh through the grooves of a record only a few thousandths of an inch wide. You hear groove displacements of the order of a few millionths of an inch. (That's like splitting a hair into one thousand pieces.) Every movement or vibration at this level can be heard enormously amplified through your speakers. For this reason it's good to set up the turntable and arm correctly so that the audio cartridge can do it's job properly.

For example a turntable significantly out of level can produce side forces on the pickup cartridge tip that will wear it more on one side than the other as well as have a slightly degrading effect on the wear of your records.

Levelness

When a turntable goes out of level, the platter bearing performance and the arm's dynamics, specifically anti-skate, are negatively affected. So be sure your turntable platter and tonearm mounting board are level - use a spirit level.

If the platter is out of level, first adjust the surface that the deck stands on. The suspension (in the case of a suspended sub-chassis design) may also need levelling if

it's subsided over time.

If the arm board is not level (which means the arm pivot is not vertical), either return it to your dealer for repair or re-level it yourself by shimming between the mounting board and it's support.

Cartridge alignment

Alignment for hi-fi cartridges needs to be optimised in three different planes. The final authority should always be your ears and preferably over an extended period of listening.

Bear in mind that each record is cut slightly differently so optimise for an overall balance of good sound over a wide range of records.

The three alignment planes are as follows. (Please note that it's the stylus, not the cartridge that is being aligned.)

Lateral tracking angle

Viewed from above, the hi-fi cartridges arcing movement across the record must maintain the stylus in the same relation to the groove as that of the cutting stylus's straight-line tracking; this is Lateral Tracking Angle, or Tangency. Apart from linear tracking arms this is always a matter of the best compromise.

Azimuth

Viewed from head on, the stylus must be perpendicular in the groove so as not to favour one groove wall, and therefore one channel, over the other wall/channel; this is Azimuth.

Vertical tracking angle (VTA)

Viewed from the side, the stylus must sit correctly in the groove, at the same angle as the original cutter; this is Vertical Tracking/Stylus Rake Angle. This alignment must be set by ear, even more than is the case with the other adjustments.

Note that because record thickness varies, set the VTA on the most commonly used thickness of record.

Cartridge alignment tools

Tools required are an alignment gauge, a ruler, a tracking force gauge, a FLAT record, a screwdriver or Allen keys of the right size (usually 2mm), a good light may also be helpful. Small needle-nose pliers and a magnifying glass all help. A good "test record" such as the Hi Fi News test record is useful.

Bear in mind that the most severe "tracking ability" tests are hopelessly unrealistic and nothing tracks properly on them.

Treat the arm with care as some parts are fragile. To

this end ensure that tightening of any bolts is carried out gently and without causing undue strain.

Tonearm wiring

Tonearm wiring uses a standard colour code for channel and polarity identification: White = L Hot, Blue = L Ground, Red = R Hot, and Green = R Ground. If the cartridge pins aren't colour-coded the same way, they will have letter identifications next to them.

Cartridge tag conduction & fit

Low level signals are unbelievably sensitive, so good conduction is essential and joints can be critical.

Make sure that the arm's wires, wire clips, and solder joints are in very good condition. At minimum, clean the contact between cartridge pins and wire clips by removing and replacing each clip. Holding the clips with needle-nose pliers can make this easier, but be careful that you don't strain the wires where they join the clip.

Check the clips for a proper fit on the cartridge pins, and adjust them if necessary. "Proper" means snug but not tight. To check clip size, hold the cartridge tail-up close to the head wires, grasp a clip firmly right behind its tubular part with the tweezers, line it up with the cartridge pin, and press. If it does not slide on with moderate force, the clip needs opening-up. If it slides on easily but flops around when attached, it needs tightening. Re-sizing is the operation most likely to detach a clip.

The trick is to avoid bending the wire at its attachment point or putting too much tension on it. To avoid either, always hold the clip with its wire slightly slack-looped behind it while adjusting. For opening a clip, hold it firmly with the tweezers or needle-noses, right behind its tubular section, and press the tip of the jeweller's screwdriver into the open end of its longitudinal slot until you see this widen very slightly. (Here's where you'll probably need the magnifier or reading glasses.). You're dealing with thousandths of an inch here, so a barely visible spreading may be all that's needed.

Try it for fit, and repeat until it does. For tightening a clip, press a toothpick inside it as far as it will go, then use the needle-nose pliers to gently squeeze together the sides of the clip near its free end, while watching the slot for any change. (Attempting to squeeze a clip without the toothpick inside it will flatten its sides.) Try it for size, and re-squeeze if necessary until the fit is correct. When it is, close up the middle section of the tube to match the end.

Static on Arm

Under certain conditions it's possible for severe static charge to build up on the arm, which then causes a noise

when the finger lift is touched.

Dry climates or air conditioned environments are the worst for this so remedies include:

- Place a pot plant in the room to get moisture into the air.
- Wipe the arm with antistatic fluid such as L'art du Son which leaves no residue (do not use furniture spray).
- Avoid Synthetic carpets and clothing.

RECORD & STYLUS CARE

Record and stylus care are big subjects well beyond the brief scope of these instructions. To help on this we've produced Youtube videos which can be found on the Origin Live Youtube channel (use google to find this).

CARE OF CARTRIDGES

Suspension Ageing

Replace your cartridge when due. Most hi-fi cartridges have a lifespan for their cantilever suspensions, which age even when not in use. This will vary from manufacturer and type of cartridge but 6 years is common.

Stylus Wear

Styli wear down due to record friction. Cleaning records and stylus properly will dramatically improve the life of both. It also increases performance significantly.

Cleaning Strategies

There are a number of strategies for cleaning styli, each with it's own merits. We recommend a combination of the below. The items concerned are available on the Origin Live website.

Small cartridge cleaning brush

These brushes are usually supplied with your cartridge. If there is a build-up of dust and dirt where the needle enters the cartridge body you should use a small soft brush to brush the debris out. Always brush from the direction of the cantilever to the stylus or you may do damage.

Passion dust Buster (use when visible contamination is present)

This helps remove fluff and particle build up on the stylus.

Cleaning fluid (use infrequently)

Lyra cleaning fluid or similar is helpful to dissolve substance build up. Some fluids dissolve glue so minimal quantity should be used on a cotton bud or brush and only damp to prevent fluid running up the cantilever by capillary action.

Green Stuff paper (use once a week or so)

This is a very fine abrasive paper that will not harm your stylus but will remove baked on substances.

RECORD CARE AND CLEANING

The stylus itself does a pretty good job of cleaning the grooves and should itself therefore be kept very clean.

Proprietary brushes etc. for cleaning records will often do little more than brush dirt deeper into the record grooves and are best avoided if possible.

High Quality Record Sleeves

Keep records in high quality non-scratch record sleeves - preferably good ones.

Record Cleaning Machines

A record cleaning machine is really the only answer for cleaning records properly as they suck out the debris and dust in the record grooves using a powerful vacuum. Tests using a microscope prove that this does the job with 100% success. The performance improvement is also very noticeable when it comes to even new records being played. We offer a number of high grade cleaning machines – see web site for details.

Cleaning Fluids

The most overlooked item in cleaning records is the Cleaning fluid itself and there are many that fail to do the job properly because they have not been developed by trained chemists. For example, Iso-propanol or detergent based cleaners may degrease the record but damage it slowly as well.

We only recommend L'Art du Son cleaning fluid which has consistently outperformed everything else in reviews. Formulated by a trained Chemist and leading turntable designer, this fluid will:

- Reduce Static charge on the record surface
- Clean grease and other contaminants
- Not damage your records
- Leave no surface residue

PACKING FOR TRANSIT

If you need to send the arm anywhere the following procedure must be followed carefully to avoid damage to

Remove the counterweight from the rear stub and wind the vta adjuster wheel up as high as possible.

Locate the armtube in the arm clip and fasten in place using wire wrap as shown below.



Polythene bag

Wire wrap (food bag tie or similar)

Place the 2 wooden packing pieces between the yoke and turret plate. This ensures the spikes are lifted clear from their cups so no damage can occur in transit. Tape the wood pieces in position of use elastic bands to ensure they cannot drop out in transit.

Pack arm in original box or use a box with bubble wrap or scrunched up newspaper.